



**AUTROL<sup>®</sup>**

# Smart Pressure Transmitter

for Differential / Gauge / Absolute Pressure Measurement



MODEL  
**APT 3100**

**DUON** System **Duon System Co., Ltd.**

60-31 GASAN-DONG GUMCHON-GU SEOUL KOREA

Tel : +82-2-860-7900

Fax : +82-2-860-7997

Web : [www.autrol.com](http://www.autrol.com)

# Smart Pressure Transmitter

## APT3100



### Function

- Flexible Sensor Input : DP, GP, AP, Vacuum
- Various Output : 4 ~20mA , Digital Signals
- Setting Various Parameters : Zero/Span, Trim, Unit, Fail-mode, etc.
- Self Diagnostic Function : Sensor, Memory A/D Converter, Power, etc
- Digital Communication with HART protocol
- Explosion-proof Approval & Intrinsic Safety Approval : KOSHA, KTL, CSA,FM, ATEX

### Description of Product

The APT3100 Smart Pressure Transmitter is a micro processor-based high performance transmitter, which has flexible pressure calibration and output, automatic compensation of ambient temperature and process variable, configuration of various parameters, communication with HART protocol. The application is very various, as measuring pressure, flow and level by application method. All data of sensor is to be input, modified and stored in EEPROM.

### Features

- Superior Performance
  - High Reference Accuracy :  $\pm 0.075\%$  of Calibrated Span
  - Long-Term Stability
  - High Rangeability ( 100 : 1 )
- Flexibility
  - Data Configuration with HART Configurator
  - Zero Point Adjustment
- Reliability
  - Continuous Self-Diagnostic Function
  - Automatic Ambient Temperature Compensation
  - Fail-mode Process Function
  - EEPROM Write Protection
  - CE EMC Conformity Standards (EN50081-2, EN50082-2)

### Functional Block Diagram

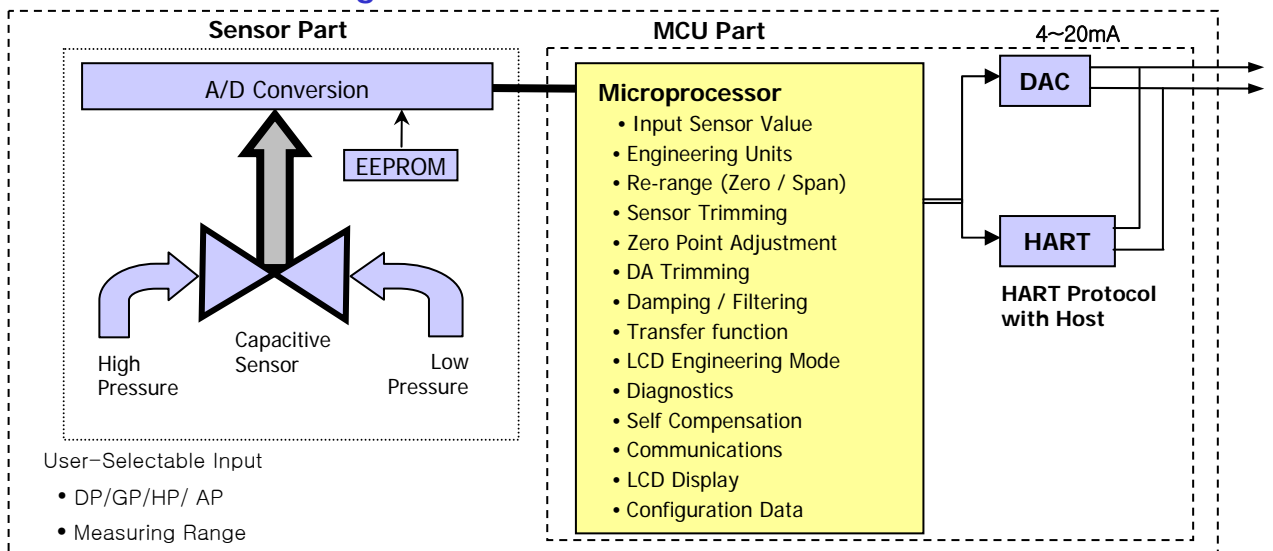

# APT3100

## Smart Pressure Transmitter

### Transmitter Description

#### Electronics Module

The Electronics module consists of a circuit board sealed in an enclosure.

There are a MCU module, a power module, an analog module, a LCD module and a terminal module in a transmitter.

The MCU module acquires the digital value from the analog module and apply correction coefficients selected from EEPROM.

The output section of the power module converts the digital signal to a 4~20 mA output.

The MCU module communicates with the HART-based Configurator or Control Systems such as DCS.

The Power module have a DC-to-DC Power conversion circuit and an Input/output isolation circuit.

An optional LCD module plugs into the MCU module and displays the digital output in user-configured unit.

#### Sensor Inputs

The model APT3100-D,G,H is available in a differential pressure sensor of a capacitance type.

The capacitance pressure sensor measures differential and gauge pressure and is commonly used in flow and level applications. Both sides in the capacitance sensor transmit process pressure from the process isolators to the sensor.

The model APT3100-A is available in a absolute pressure sensor of a piezo-resistive type and measures absolute pressure.

The sensor module converts the capacitance or the resistance to the digital value.

The MCU module calculates the process pressure based on the digital value.

The sensor modules include the following features

- 0.075% accuracy – the most accurate sensor in the industry.
- The software of the transmitter compensates for the thermal effects, improving performance.
- Precise Input Compensation during operation is achieved with temperature and pressure correction coefficients that are characterized over the range the transmitter and stored in the sensor module EEPROM memory
- EEPROM stores sensor information and correction coefficients separately from MCU module, allowing for easy repair, reconfiguration and replacement

#### Basic Setup

ATP3100 Pressure transmitter can be easily configured from any host that support the HART protocol.

- Operational Parameters.
- 4~20mA Points (Zero/Span)
- Engineering Units
- Damping Time : 0.25 ~ 60 sec
- Tag : 8 alphanumeric characters
- Descriptor : 16 characters
- Message : 32 characters.
- Date : day/month/year

#### Calibration and Trimming

- Lower/Upper Range (zero/span)
- Sensor Zero Trimming
- Zero Point Adjustment
- DAC Output Trimming
- Transfer Function
- Self-Compensation

#### Self-Diagnosis and Others

- CPU & Analog Module Fault Detection
- Communication Error
- Fail-mode Handling
- LCD Indication
- Temperature Measurement of Sensor Module

**Function**

**Range and Sensor Limits**

- Refer to Table 1

**Zero and Span Adjustment Limits**

- Zero and span values can be set anywhere within the range limits stated in Table 1. Span must be greater than or equal to the minimum span stated in Table 1

**Output (Analog Current and Digital Data)**

- Two wire 4~20mA user-configurable for linear or square root output, digital process value superimposed on 4~20mA signal, available to any host that conforms to the HART protocol

**Power Supply & Load Requirement**

- **External power supply required.** Transmitters operate on 11.9 to 45 V dc.
  - \* 250 ohm load-- 17.4 Vdc
  - \* up to a 550 ohm load -- 24 Vdc

Max. Loop Resistance = ( E - 11.9 ) / 0.022  
(E = Power Supply Voltage)

- **Supply Voltage**
  - 11.9 ~ 45 Vdc -- operation
  - 17.4 ~ 45 Vdc -- HART Communications
  - 11.9 ~ 42 Vdc -- CSA Approval
- **Loop Load**
  - 0 ~ 1500 ohm -- Operation
  - 250 ~ 550 ohm -- HART Communications

**EMC Conformity Standards**

- EMI (Emission) – EN50081-2:1993
- EMS (Immunity) – EN50082-2:1995

**Update Time and Turn-On Time**

- Update Time : 0.12 seconds
- Turn-On Time : 3 seconds

**Failure Mode**

- Fail High : Current ≥ 21.75 mA
- Fail Low : Current ≤ 3.75 mA

**Storage Temperature**

- -40°C to 85°C (without condensing)

**Process Temperature Limits**

- (Range codes and approval codes may effect limits)
- -40°C to 120°C ( -40 to 248 °F )

**Isolation**

- Input/output isolated to 500Vrms (707 Vdc)

**Working Pressure Limits (silicone oil)**

- **Model DP & GP** 0 ~ 13.79 MPa --- # 3 ~ 8
- **Model GP** 0 ~ 31.02 MPa --- # 9  
0 ~ 51.71 MPa --- # 0
- **Model HP** 0 ~ 31.02 MPa --- # 4 ~ 7
- **Model AP** 0 ~ 400 KPa --- # 4  
0 ~ 1500 KPa --- # 5  
0 ~ 3000 KPa --- # 6

**Hydrostatic Test Pressure**

- **Model DP** 3000 psi (20.7 MPa)
- **Model HP** 6750 psi (46.5 MPa)
- **Model GP** 2000 psi (13.8 MPa) --- # 3 ~ 8  
4500 psi (31.0 MPa) --- # 9  
7500 psi (51.7 MPa) --- # 0
- **Model AP** 58 psi (400 KPa) --- # 4  
218 psi (1500 KPa) -- # 5  
435 psi (3000 KPa)--- # 6

**Burst Pressure**

- **Model DP,GP & HP** -----10000 psi (68.9MPa)
- **Model AP** ----- 2000 psi (13.8MPa)

**5 Digit LCD**

- Express all pressure unit and flow unit.
- Use 5 digit.
- Select decimal place (0 to 4)



# APT3100

## Smart Pressure Transmitter

### Physical Specifications

#### Wetted Materials

- Isolating Diaphragms ---- 316L SST, Monel, Tantalum, HAST-C
- Drain/Vent Valves ----- 316 SST, HAST-C
- Flanges and Adapters ---- 316 SST, HAST-C
- O-ring ----- Viton, PTFE

#### Non-wetted materials

- Fill Fluid ----- Silicone oil or Inert fill
- Bolts ----- Stainless Steel
- Electronics Housing -- Aluminum, Flameproof and Waterproof (IP67)
- Cover O-ring ----- Buna-N
- Paint ----- Epoxy-Polyester or Polyurethane
- Mounting Bracket ---- 2-inch Pipe, 304 SST, Painted Carbon Steel with 304 SST U-bolt
- Nameplate ----- 304 SST

#### Electrical connections

- 1/2-14 NPT conduit with M4 Screw Terminals

#### Process Connections

- 1/4-18 NPT on 2.126 inch (54.0 mm) centers on flanges for Standard
  - 1/2-14 NPT on Process Adapter (option)
- \* Refer to drawing in the last page

#### Weight

- 3.9 kg ( excluding options )

### Hazardous Location Certifications (option)

#### CSA (Canadian Standards Association) Approvals

##### C1 Code :

“SEAL NOT REQUIRED”

Explosion proof for Class I, Division 1, Groups A, B, C & D

Dust-ignition proof for Class II, Division 1, Groups E, F & G ; Class III

Flameproof for Class I, Zone 1 : Ex d IIC “ T6, See Instruction for temperature code if process temperature above 85 °C ”

Class I, Division 2, Groups A, B, C, D ;  
Class II, Division 2, Groups E, F, G ;  
Class III T4

Nonsparking Equipment for Class I Zone 2 :  
Ex nA IIC T4

Enclosure : Type 4x, IP66

Power Supply : 11.9 to 42 Vdc Max.

Output Signal : 4 to 20 mA + HART

Ambient Temp. : -20 to 60 °C

#### KOSHA Approvals (KOSHA: Korea Occupational Safety & Health Agency) **K1 Code :**

Flameproof for Class I, Zone 1 : Ex d IIC T6, IP67

Ambient Temperature : -20 to 60 °C

Max. Process Temperature : 80 °C

Power Supply : Max. 45 Vdc

Output : 4 to 20 mA + HART, Max. 22 mA

#### KTL Certification (KTL: Korea Testing Laboratory)

##### K2 Code :

Intrinsic Safety: Ex ia IIC T5

Ambient Temperature : -20 to 60 °C

Max. Process Temperature : Max. 100 °C

Entity Parameter : Umax = 40Vdc, Imax = 165mA,

Pmax = 0.9W

#### FM (Factory Mutual explosion proof) Approvals

##### F1 Code :

Explosion proof for Class I, Division 1

Groups A, B, C and D

Dust-ignition proof for Class II, Division 1, Groups E, F and G

Dust-ignition proof for Class II, Division 1

“T6, see instruction for temperature code if process temperature above 85°C”

Ambient Temperature : -20 to 60°C

Enclosure: indoors and outdoors, NEMA Type 4X

Conduit seal required within 18” for Group A only.

Nonincendive for Class I, Division 2, Groups A, B, C & D;

Class II, Division 2, Groups E, F & G; and Class III, Division 1,

Temperature Code T4

Ambient Temperature : -20 to 60°C

Enclosure: indoors and outdoors, NEMA Type 4X

#### ATEX Approvals

##### E1 Code :

ATEX Certificate number : KEMA07ATEX0103

CE 0344  II 2 G Ex d IIC T6 or T5

Operating Temperature: -20°C ≤ Tamb ≤ +60°C

T6 for process < 85°C; T5 for process < 100°C

## General Specifications

(Rangeability : #2=20:1 / #3=50:1 / 4~0=100:1)

### 1. APT3100 Pressure Sensor Range & URL

< Table 1 >

Range Code	DP/GP/HP					AP	
	Calibrated Span (KPa)	Upper Range (URL) (KPa)	Lower Range (LRL) (KPa)			Calibrated Span (KPa)	Range (KPa)
			D.P	G.P	H.P		
2	0.075 ~ 1.5	1.5	-1.5	-1.5	NA	NA	NA
3	0.25 ~ 7.5	7.5	-7.5	-7.5	NA	NA	NA
4	0.373 ~ 37.3	37.3	-37.3	-37.3	-37.3	2 ~ 200	0 ~ 200
5	1.865 ~ 186.5	186.5	-186.5	-100	-186.5	10 ~ 1000	0 ~ 1000
6	6.9 ~ 690	690	-690	-100	-690	20 ~ 2000	0 ~ 2000
7	20.68 ~ 2068	2068	-2068	-100	-2068	NA	NA
8	68.95 ~ 6895	6895	-6895	-100	NA	NA	NA
9	206.8 ~ 20680	20680	NA	-100	NA	NA	NA
0	413.7 ~ 41370	41370	NA	-100	NA	NA	NA

Range Code	KPa	Kg/cm <sup>2</sup>	bar	psi	inH <sub>2</sub> O@4℃	mmH <sub>2</sub> O@4℃	inHg@0℃
2	1.5	0.015	0.015	0.217	6	152	0.442
3	7.5	0.076	0.075	1.087	30	765	2.215
4	37.3	0.38	0.373	5.410	149	3804	11.014
5	186.5	1.902	1.865	27.049	749	19018	55.072
6	690	7.036	6.900	100.073	2773	70361	203.750
7	2068	21.088	20.680	299.930	8310	210878	610.660
8	6895	70.309	68.950	1000.009	27708	703097	2036.025
9	20680	210.876	206.800	2999.303	83105	2108781	6106.597
0	41370	421.856	413.700	6000.211	166085	4218566	12216.550

### 2. Electrical Specifications

Power Supply	11.9 ~ 45 Vdc	Output Signal	4 ~ 20 mA dc / HART
HART loop resistance	250 ~ 550 ohm	Isolation	500 Vrms (707 Vdc)

### 3. Performance Specifications

Reference Accuracy	± 0.075% of Span (0.1URL ≤ Span ≤ URL)	Ambient Temperature	-40 ~ +85 ℃
	± [0.025+0.005x(URL/Span)]% of Span (0.01URL ≤ Span < 0.1URL)	LCD Meter Ambient Temp.	-30 ~ +80 ℃
		Humidity Limits	5% ~ 100% RH
Ambient Temp. Effect	± [0.019%URL+0.125% Span] / 28 ℃	Process Temperature Limits	-40℃ ~ +120 ℃
Stability	±0.125% URL for 12 Months	Power Supply Effects	±0.005% of Span per Volt
Static Pressure Effects	±0.1% of URL per 7MPa (Zero Error)	Mounting Position Effects	Zero Shift up to 350Pa
	±0.2% of Reading per 7Mpa (Span Error)		No Span Effect

### 4. Physical Specifications

Isolating Diaphragm	316L SST	Process Connection Size	1/4 - 18 NPT
Drain & Vent Valve	316 SST	( Adapter – Option)	1/2 – 14 NPT
Flange & Adapter	316 SST	Electrical Connections	1/2 – 14 NPT with M4
O-ring	Viton, PTFE	Weight (excluding Option Items)	3.9 Kg
Electronic Housing	Aluminum	2" Pipe Stanchion Type bracket	Angle or Flat type
Bolts & Bolting Flange	304 SST	Housing Class	Waterproof (IP67), 4X, IP66

### 5. Hazardous Location Certifications (option)

Korea Standards Approval	Overseas Standards Approval
Flameproof Approval : Ex d IIC T6 (KOSHA)	CSA Explosion proof Approval
Intrinsic Safety Approval : Ex ia IIC T5 (KTL)	FM Explosion proof Approval
	ATEX Flame proof Approval

### Ordering Information

MODEL	Code	Description					
APT3100	-DP	Differential Pressure Transmitter (Static Pressure 13.79 MPa / 2000psi)					
	-GP	Gauge Pressure Transmitter					
	-HP	Differential Pressure Transmitter for High Line Pressure (Static Pressure 31.02MPa / 4500psi)					
	-AP	Absolute Pressure Transmitter					
Ranges		DP/GP/HP					*AP
		Calibrated Span Min. to Max	Lower Range Limit			Upper Range Limit	Range APT3100-A
			APT3100-D	APT3100-G	APT3100-H		
	2	0.075 ~ 1.5 KPa (0.302~6.022 inH <sub>2</sub> O)	-1.5 KPa (-6.022 inH <sub>2</sub> O)	-1.5 KPa (-6.022 inH <sub>2</sub> O)	NA	1.5 KPa (6.022 inH <sub>2</sub> O)	NA
	3	0.15 ~ 7.5 KPa (0.6~30 inH <sub>2</sub> O)	-7.5 KPa (-30 inH <sub>2</sub> O)	-7.5 KPa (-30 inH <sub>2</sub> O)	-7.5 KPa (-30 inH <sub>2</sub> O)	7.5 KPa (30 inH <sub>2</sub> O)	NA
	4	0.373 ~ 37.3 KPa (1.5~150 inH <sub>2</sub> O)	-37.3 KPa (-150 inH <sub>2</sub> O)	-37.3 KPa (-150 inH <sub>2</sub> O)	-37.3 KPa (-150 inH <sub>2</sub> O)	37.3 KPa (150 inH <sub>2</sub> O)	NA
	5	1.865 ~ 186.5 KPa (7.5~750 inH <sub>2</sub> O)	-186.5 KPa (-750 inH <sub>2</sub> O)	-100KPa (-14.6 psi)	-186.5 KPa (-750 inH <sub>2</sub> O)	186.5 KPa (750 inH <sub>2</sub> O)	0~200 KPa
	6	6.9 ~ 690 KPa (1~100 psi)	-690 KPa (-100 psi)	-100KPa (-14.6 psi)	-690 KPa (-100 psi)	690 KPa (100 psi)	0~1000 KPa
	7	20.68 ~ 2068 KPa (3~300 psi)	-2068 KPa (-300 psi)	-100KPa (-14.6 psi)	-2068 KPa (-300 psi)	2068 KPa (300 psi)	0~2000 KPa
	8	68.95 ~ 6895 KPa (10~1000 psi)	-6895 KPa (-1000 psi)	-100KPa (-14.6 psi)	NA	6895 KPa (1000 psi)	NA
	9	206.8 ~ 20680 KPa (30~3000 psi)	NA	-100KPa (-14.6 psi)	NA	20680 KPa (3000 psi)	NA
	0	413.7 ~ 41370 KPa (60~6000 psi)	NA	-100KPa (-14.6 psi)	NA	41370 KPa (6000 psi)	NA
X	Special						
Mounting Flange /Material		Body		Vent Plug		Diaphragm	
	M11	316 SST		316 SST		316L SST	
	M12	316 SST		316 SST		HAST - C	
	M13	316 SST		316 SST		Monel	
	M14	316 SST		316 SST		Tantalum	
	M21	HAST - C		HAST - C		HAST - C	
	M22	HAST - C		HAST - C		Monel	
	M23	HAST - C		HAST - C		Tantalum	
Hazardous Location Certifications	K0	Maker Standard (Waterproof : IP67 )		E1	ATEX(KEMA) Flameproof		
	K1	KOSHA Flameproof Approval : Ex d IIC T6		*E2	ATEX(KEMA) Intrinsic Safety		
	*K2	KTL Intrinsic Safety Approval : Ex ia IIC T5		F1	FM Explosion proof		
	C1	CSA Explosion proof		*F2	FM Intrinsic Safety		
	*C2	CSA Intrinsic Safety					
Fill Fluid	1	Silicone		*2	Inert fill fluid		
Process Connection	S	1/4 - 18 NPT (Standard)		O	1/2 - 14 NPT Female (Adapter)	X	Special
Electrical Connection	1	1/2-14NPT Epoxy-Polyester Painted Aluminum		2	G1/2 Epoxy-Polyester Painted Aluminum	X	Special
Option	M1	LCD Indicator(5digit)		MP	Multi-Planar		
	W	SUS 304 Bolts and Nuts		LP	Lighting Protector		
	C6	Engineering Unit		ET	External Terminal Block		
	C7	Custom Calibration					
	K	Oil Free Finish					
	F1	Side Vent / Drain Top					
	F2	Side Vent / Drain Bottom					
	2W	2 Way Manifold (SST)					
	3W	3 Way Manifold (SST)					
	5W	5 Way Manifold (SST)					
Option	BA	Stainless Steel Bracket (Angle type) with SST Bolts					
	BF	Stainless Steel Bracket (Flat type) with SST Bolts					
	CA	Painted Steel Mounting Bracket (Angle Type) with SST Bolts					
	CF	Painted Steel Mounting Bracket (Flat Type) with SST Bolts					
	T	Teflon O-Ring (Wetted Part)					



Example : APT3100-D5-M11-C1-1-S-1-M1-W-BA

Note 1 : Request to manufacturer for Draft Range, Absolute (small pressure and vacuum) and Items marked " \* " before order

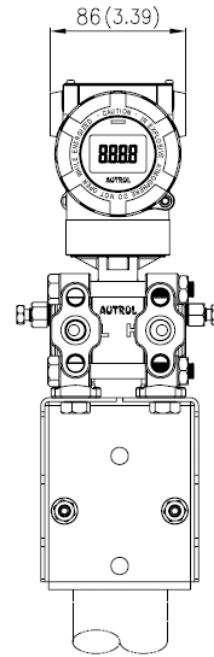
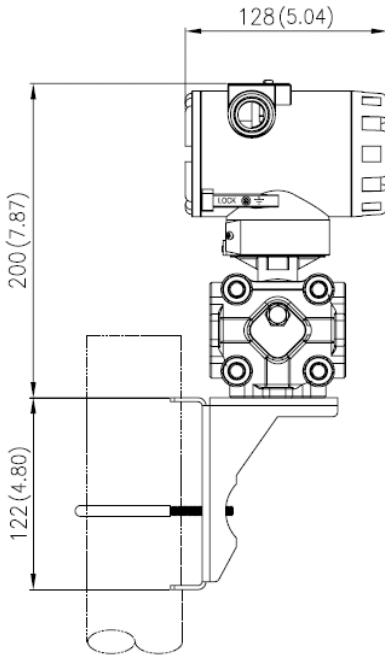
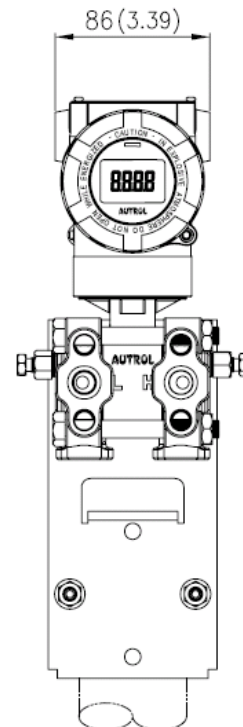
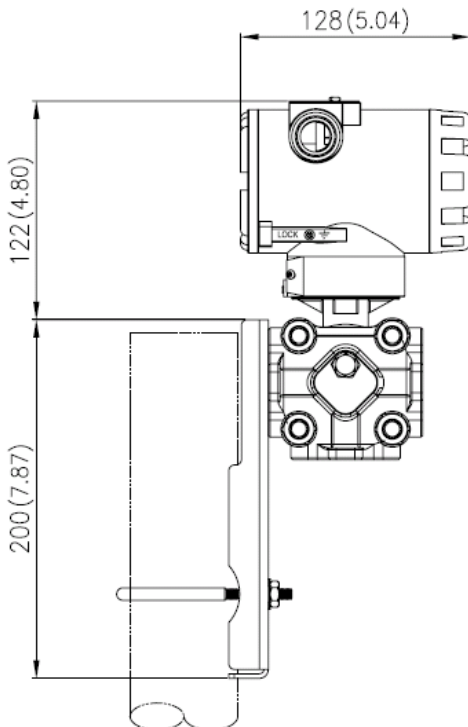
**Installation with mounting bracket****2" Pipe Mounting Bracket  
Model Angle Type****2" Pipe Mounting Bracket  
Model Flat Type**

# APT3100 Smart Pressure Transmitter

## Connection Diagram of Signal, Power, HHT for Transmitter

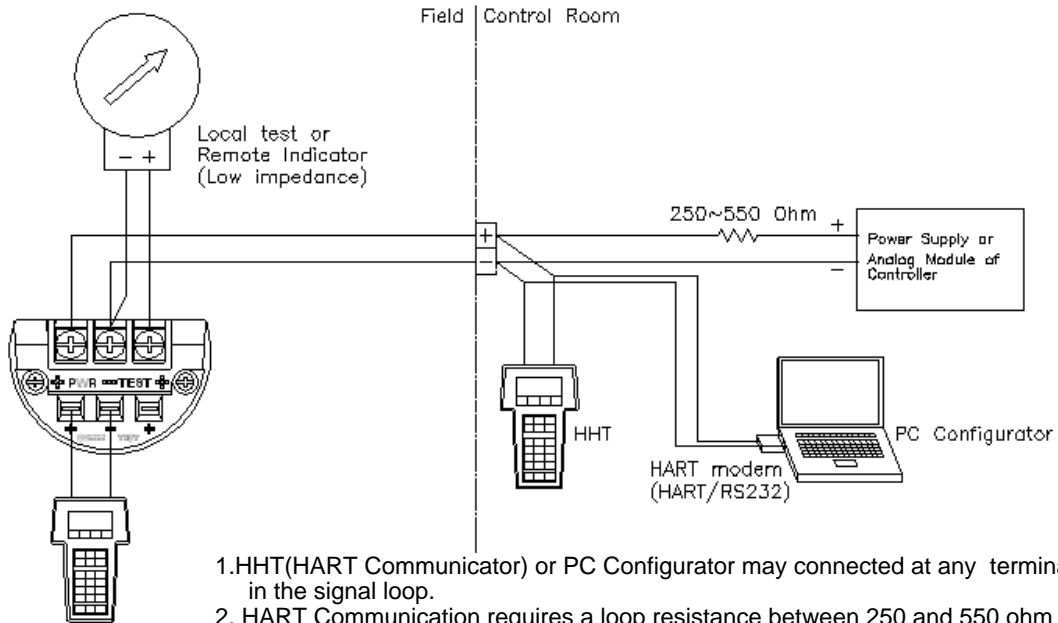

1. HHT (HART Communicator) or PC Configurator may be connected at any termination point in the signal loop.
  2. HART Communication requires a loop resistance between 250 and 550 ohm @ 24 Vdc
  3. Transmitter operates on 11.9 to 45.0 Vdc transmitter terminal voltage.
- [ Applied Power ]
- \* 11.9 ~ 45.0 Vdc for General Operation
  - \* 17.4 ~ 45.0 Vdc for HART Communication
  - \* 17.4 ~ 42.0 Vdc for CSA Approval (Power supply must not exceed 42.0 Vdc)

## Dimensions of Transmitter (mm)

